

SKYCATCHER

MODEL 162



Specification & Description

Initial _____

January 2012

Exhibit "A"



SPECIFICATION AND DESCRIPTION

EXHIBIT "A"

JANUARY 2012



January 2012

INTRODUCTION

This Specification and Description is published for the purpose of providing general information for the evaluation of the design, performance, and equipment of the Cessna model 162. This document supersedes all previous Specification and Description documents and describes only the Model 162, its powerplant and equipment.

Also included are the warranties applicable to the Model 162 aircraft, the Teledyne Continental Motors O-200D engine, applicable propeller and the OEM-installed avionics. In the event of any conflict or discrepancy between this document and the terms and conditions of the purchase agreement to which it is incorporated, the terms and conditions of the purchase agreement govern.

Due to the time span between the date of this Specification and Description and the scheduled delivery date of the aircraft, Cessna reserves the right to revise the "Specification" whenever occasioned by product improvements, government regulations or other good cause.

For additional information contact:

Cessna Aircraft Company
Single Engine Piston Aircraft
2625 S. Hoover Rd.
Wichita, Kansas 67215
1-800-4-CESSNA
www.se.cessna.com



TABLE OF CONTENTS

Cessna Model 162 Specification and Description

| Section | Page |
|--|------|
| 1. General Description | 3 |
| 1.1 Certification | 3 |
| 1.2 Approximate Dimensions | 3 |
| 2. Performance | 6 |
| 3. Structural Design Criteria | 6 |
| 4. Fuselage | 6 |
| 5. Wing | 6 |
| 6. Empennage | 6 |
| 7. Landing Gear | 6 |
| 8. Powerplant | 7 |
| 9. Systems | 7 |
| 10. Avionics and Instrumentation | 7 |
| 11. Interior | 7 |
| 12. Exterior Striping Options | 7 |
| 13. Limited Warranties | 8 |
| 13.1. Cessna Skycatcher Model 162 Piston Aircraft Limited Warranty | 8 |
| 13.2. Garmin Standard Avionics Limited Warranty | 8 |
| 13.3. Teledyne Continental Motors, Inc. New Engine Warranty | 9 |
| 13.4. McCauley Propeller Systems Standard Limited Warranty | 11 |
| 13.5. Cessna Skycatcher Model 162 Paint Warranty | 12 |
| FIGURE I — MODEL 162 EXTERIOR DIMENSIONS | 4 |
| FIGURE II — MODEL 162 INTERIOR DIMENSIONS | 5 |

1. GENERAL DESCRIPTION

The Cessna model 162 is an all-metal, single engine piston, high-wing monoplane with a two-person seating capacity including the pilot. Suitable allowance for luggage is provided aft of the seats. The 162 is equipped per FAR 91.205 to meet both Day and Night VFR flight requirements. Cessna's worldwide network of authorized service centers provides a complete source for all servicing needs.

1.1 Certification

The Model 162 is designed and built to comply with the American Society for Testing and Materials International (ASTM) standards for Light Sport Aircraft and it meets

the limitation and Special Certificate of Airworthiness requirements for a Light Sport category aircraft as defined by the FAA in CFR Part 1.1 and CFR Part 21.190.

The Purchaser is responsible for obtaining aircraft operating approval from the relevant civil aviation authority prior to aircraft delivery.

1.2 Approximate Dimensions

| | |
|--------------------------|--|
| Engine | Continental O-200D |
| Horsepower | 100 hp at 2750 RPM |
| Propeller | 2-Blade McCauley Composite Fixed Pitch Propeller |
| Service Ceiling | 14,625 ft (4,457.7 m) |
| Maximum Ramp Weight | 1324 lbs (600 kg) |
| Maximum Gross Weight | 1320 lbs (598.7 kg) |
| Standard Empty Weight | 843 lbs (382.3 kg) |
| Maximum Useful Load | 481 lbs (218.1 kg) |
| Fuel Capacity (Usable) | 24 gal (90.85 l) |
| Overall Height | 7 ft 4 in (2.23 m) |
| Overall Length | 22 ft 1 in (6.80 m) |
| Wing Span | 30 ft (9.14 m) |
| Horizontal Tail Span | 9 ft 10 in (3.2 m) |
| Cabin Width at Shoulders | 44.3 in (112.4 cm) |

1. GENERAL DESCRIPTION (Continued)

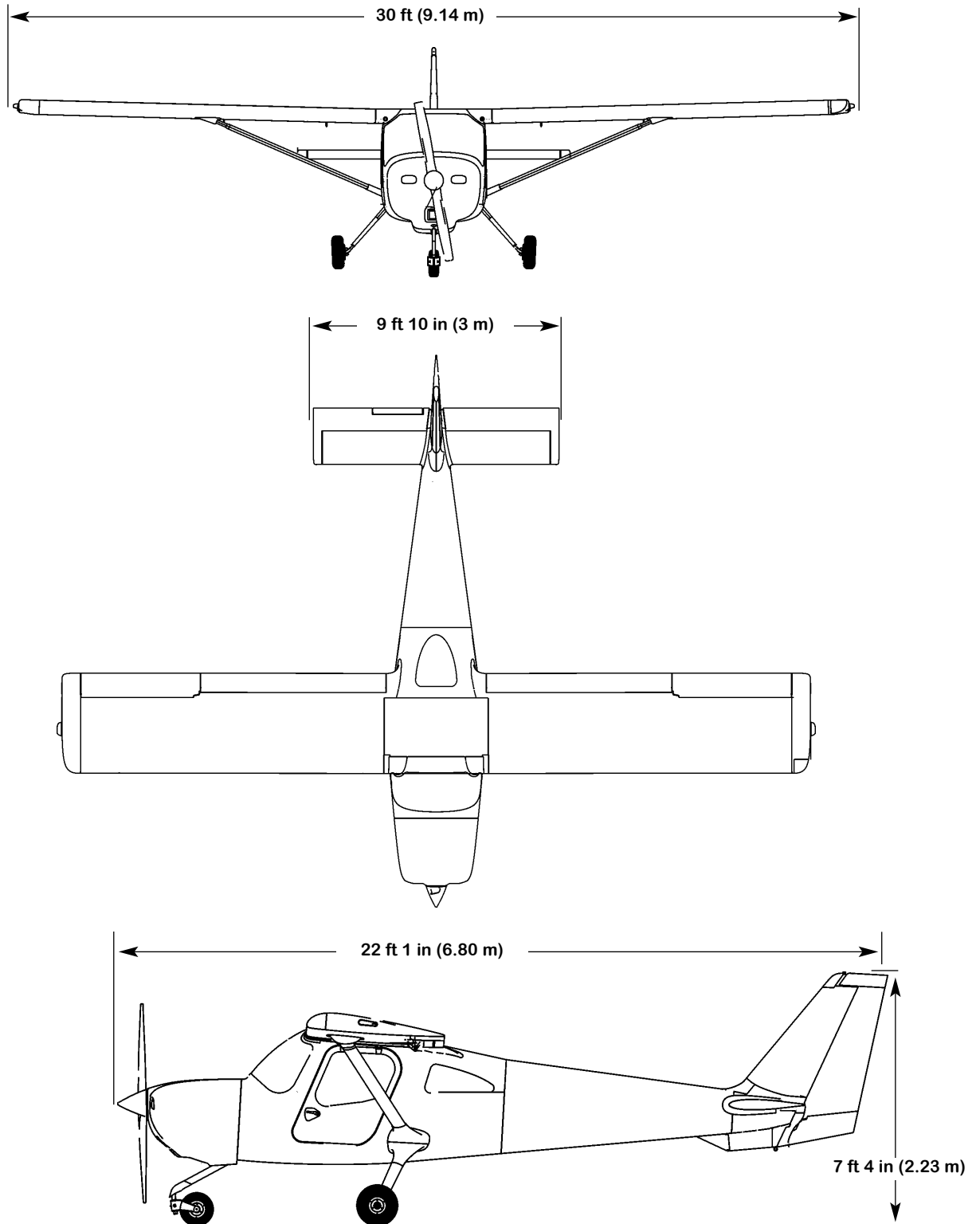
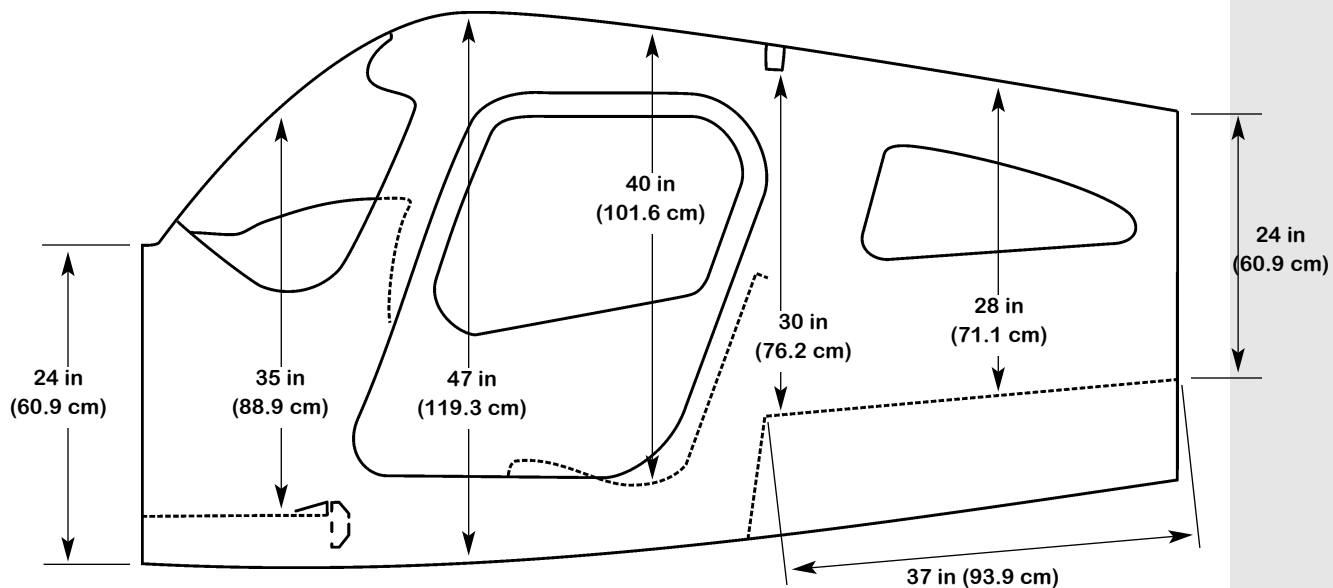
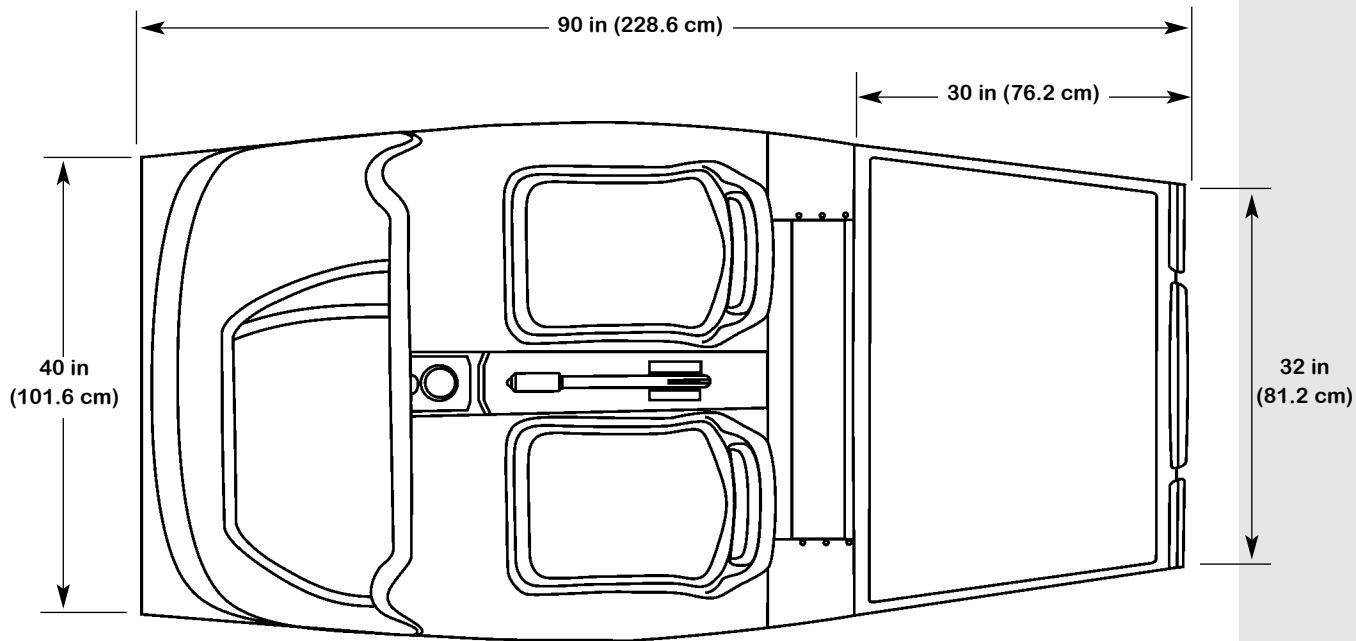

FIGURE I — MODEL 162 EXTERIOR DIMENSIONS

1. GENERAL DESCRIPTION (Continued)



Cabin Height Dimensions



Cabin Width Dimensions

FIGURE II — MODEL 162 INTERIOR DIMENSIONS



2. PERFORMANCE

All performance data is based on the standard aircraft configuration, operating in International Standard Atmosphere (ISA) conditions with zero wind. Takeoff and landing field lengths are based on a level, hard surface,

dry runway. Actual performance will vary with individual airplanes and other factors such as environmental conditions, aircraft configuration, and operational/ATC procedures.

| | |
|---|------------------------------|
| Takeoff Distance S.L. (Ground Roll) | 640 ft (195 m) |
| Takeoff Distance S.L. (To Clear 50 ft Obstacle) | 1138 ft (347 m) |
| Max Climb Rate S.L. | 880 fpm (268.2 m) |
| Max Speed S.L. | 118 kts (219 km/hr, 136 mph) |
| Max Range and Endurance at 6,000 ft | 440 nm / 5.7 hrs |
| Cruise Speed (69% pwr. at 6,000 ft) | 109 kts (202 km/hr, 125 mph) |
| Cruise Range and Endurance (69% pwr. at 6,000 ft) | 336 nm / 3.1 hrs |
| Landing Distance (Ground Roll) | 671 ft (205 m) |
| Landing Distance (To Clear 50 ft Obstacle) | 1369 ft (417 m) |

(Performance shown with 30 minutes of fuel reserve)

3. STRUCTURAL DESIGN CRITERIA

The airframe will be designed and constructed to meet the requirements presented in ASTM standard F2245 "Standard Specification for Design and Performance of a Light Sport Airplane".

4. FUSELAGE

The fuselage will be constructed primarily of aluminum alloy materials. The semi-monocoque structure will consist of frames and stringers covered by sheet aluminum

skin. A left hand and right hand door are used to allow access for the pilot and passenger.

5. WING

The wing will be constructed primarily of aluminum alloy materials and incorporates a custom designed airfoil. The wing structure uses a two spar design with a strut

that attaches to the forward spar. Slotted flaps are used to further lower the stall speed. An integral fuel tank will be incorporated in each wing.

6. EMPENNAGE

The horizontal tail will be a fixed design with two elevators. Pitch trim will be provided by a single trim tab

mounted on the right hand elevator. The rudder will not have a trim tab.

7. LANDING GEAR

The main landing gear will use high strength, tapered steel tubes to provide the necessary shock absorption.

wheel steering. Toe brakes will be provided at both cockpit seats.

Each main wheel will be equipped with toe actuated disc brakes. The differential braking will be used for nose

8. POWERPLANT

The Teledyne Continental Motors O-200D is an air-cooled, horizontally opposed, four cylinder, naturally aspirated, spark ignited, four stroke, direct drive engine incorporating a wet sump, updraft intake, carburetor, down draft tuned exhaust system w/ EGT sensors and oil quick drain.

The engine is designed with the capability to operate on 100LL aviation fuel, and has a maximum continuous rating of 100 hp at 2800 RPM with a compression ratio of 8.5:1. The time between overhaul is 2000 hours or 12 years, whichever occurs first.

9. SYSTEMS

The flight controls will consist of dual control sticks, which provide movement to the elevator and ailerons. Rudder pedals, with differential toe brakes, will provide control to the rudder and brakes. A mechanical flap lever will be located between the two occupants to provide

movement to the flaps. Electric pitch trim will be used. A single buss 14 Volt electrical system will be used, with power generated by a 40 amp engine driven alternator. A ground service receptacle is included. Position, anti-collision and landing lights are standard.

10. AVIONICS AND INSTRUMENTATION

A dual Garmin G300 display will provide primary flight and engine information in a split screen or PFD/MFD format. A Garmin SL40 Com radio, PM3000 Intercom,

Garmin GTX327 Mode C transponder, and a 121.5/233 Mhz ELT are standard equipment.

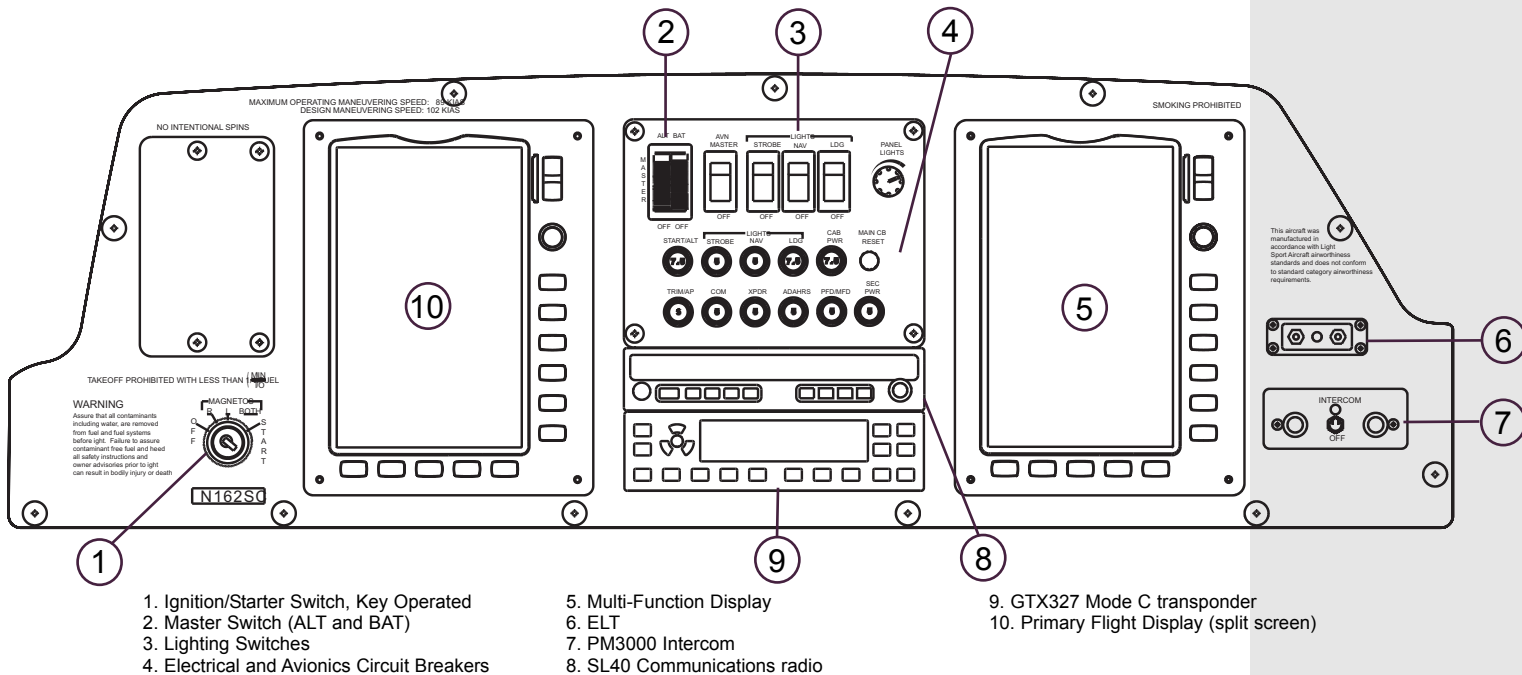

11. INTERIOR

- Two Metal Framed Seats with Cloth Wrapped Inserts
- LED Overhead Panel Lighting
- Neutrally Painted Interior
- Cabin Door Armrests
- Sunvisor
- Center Console containing Map and General Storage
- 2.5 (.35 m³) Cubic Foot Baggage Area
- Baggage Net

12. EXTERIOR

- Black Vinyl and Medium Silver Metallic Stripes
- Medium Silver Metallic vinyl Cessna logo, SkyCatcher and Light Sport Logo
- Black Vinyl registration number



13. LIMITED WARRANTIES

13.1 Cessna Skycatcher Model 162 Piston Aircraft Limited Warranty (Limited Warranty)

Cessna warrants the aircraft and all parts included therein to be free from defects in material and workmanship under normal use and service for a period of twenty-four (24) months or 2,000 hours (whichever occurs first) after the warranty start date, except as hereafter noted. Engines, engine part accessories, avionics, batteries and propellers are specifically excluded from this warranty. Paint and graphics warranties are addressed separately.

Spare parts sold by Cessna, excluding engines, engine part accessories, avionics, and propellers are warranted for six (6) months after installation, except as hereafter noted.

Cessna's obligation under this warranty is limited to repairing or replacing, at its option, with exchange, overhauled, or new parts, items found defective by Cessna's examination which are returned at the owner's expense within the applicable twenty-four (24) months or 2,000 hours (whichever occurs first) or, for spare parts, the remaining portion of the applicable six (6) month warranty period.

A new warranty period is not established for replacement parts. Replacement parts are warranted only for the remainder of the applicable twenty-four (24) months or 2,000 hours (whichever occurs first) or, for spare parts, the remaining portion of the applicable limited warranty period.

The repair or replacement of defective parts under this warranty will be made without charge to the owner for parts and labor for removal, installation and/or actual repair, except that the owner shall pay all import duties and sales and use taxes on replacements and repairs.

This limited warranty does not apply to parts subjected to misuse, negligence, improper installation, accident, alteration; repairs not authorized by Cessna; normal maintenance services (cleaning, control rigging, brake and other mechanical adjustments, maintenance inspections, etc.); replacement of service items (light bulbs, brake linings, filters, hoses, tires, cowl mounts, etc.); or to normal deterioration of soft trim or appearance items (paint, upholstery, rubber-like items, etc.) due to corro-

sion, wear and exposure.

WITH THE EXCEPTION OF THE WARRANTY OF TITLE, TO THE EXTENT ALLOWED BY APPLICABLE LAW, THIS WARRANTY IS EXPRESSLY IN LIEU OF ANY OTHER WARRANTIES, EXPRESSED OR IMPLIED IN FACT OR BY LAW, INCLUDING ANY IMPLIED WARRANTY OF MERCHANTABILITY OR FITNESS FOR A PARTICULAR PURPOSE. THE REMEDIES OF REPAIR OR REPLACEMENT AS ABOVE SET FORTH ARE THE ONLY REMEDIES UNDER THIS WARRANTY. CESSNA DISCLAIMS ANY OBLIGATION OR LIABILITY WHETHER IN CONTRACT OR IN TORT (AND WHETHER FOR NEGLIGENCE, STRICT LIABILITY, PRODUCT LIABILITY OR OTHERWISE), INCLUDING LOSS OF USE OF THE PRODUCT WARRANTED, LOSS OF TIME, INCONVENIENCE, COMMERCIAL LOSS OR ANY OTHER DIRECT, CONSEQUENTIAL, SPECIAL OR INCIDENTAL DAMAGES. THIS WARRANTY IS IN LIEU OF ANY OTHER OBLIGATION OR LIABILITY OF CESSNA OF ANY NATURE WHATSOEVER BY REASON OF THE MANUFACTURE, SALE OR LEASE OF SUCH AIRCRAFT PRODUCTS AND CESSNA NEITHER ASSUMES NOR AUTHORIZES ANYONE TO ASSUME FOR IT ANY OTHER OBLIGATION OR LIABILITY IN CONNECTION WITH SUCH AIRCRAFT PRODUCTS.

13.2 Garmin Standard Avionics Limited Warranty (Limited Warranty)

Aircraft OEM-Installed Avionics 2-Year Limited Warranty Policy:

The GARMIN G300 Components are warranted to be free from defects in materials or workmanship for two years from the date of warranty activation. The SL40 Com Radio and the GTX327 Transponder are warranted to be free from defects in materials or workmanship for two years from the date of warranty activation. Within this period, GARMIN International, Inc. will at its sole option, repair or replace any components which fail in normal use. Such repairs or replacement will be made at no charge to the customer for parts or labor, provided that the customer shall be responsible for any transportation cost. This warranty does not cover failures due to abuse, misuse, accident or unauthorized alteration or repairs.



13. LIMITED WARRANTIES (Continued)

THE WARRANTIES AND REMEDIES CONTAINED HEREIN ARE EXCLUSIVE AND IN LIEU OF ALL OTHER WARRANTIES EXPRESS OR IMPLIED OR STATUTORY, INCLUDING ANY LIABILITY ARISING UNDER ANY WARRANTY OF MERCHANTABILITY OR FITNESS FOR A PARTICULAR PURPOSE, STATUTORY OR OTHERWISE. THIS WARRANTY GIVES YOU SPECIFIC LEGAL RIGHTS, WHICH MAY VARY FROM STATE TO STATE.

IN NO EVENT SHALL GARMIN BE LIABLE FOR ANY INCIDENTAL, SPECIAL, INDIRECT OR CONSEQUENTIAL DAMAGES, WHETHER RESULTING FROM THE USE, MISUSE OR INABILITY TO USE THIS PRODUCT OR FROM DEFECTS IN THE PRODUCT.

Some states do not allow the exclusion of incidental or consequential damages, so the above limitations may not apply to you.

GARMIN retains the exclusive right to repair or replace the product or offer a full refund of the purchase price at its sole discretion. SUCH REMEDY SHALL BE YOUR SOLE AND EXCLUSIVE REMEDY FOR ANY BREACH OF WARRANTY.

To obtain warranty service, contact your local GARMIN authorized Service Center. For assistance in locating a Service Center near you, call GARMIN Customer Service at one of the numbers shown below.

GARMIN International
1200 East 151st Street
Olathe, Kansas 66062, U.S.A.
Toll free: 1-800-800-1020
Phone: 1-913-397-8200
FAX: 1-913-397-0836

GARMIN (Europe) Ltd.
Unit 5, The Quadrangle
Abbey Park Industrial Estate
Romsey, SO51 9AQ, U.K.
Phone: 44-1794-519944
FAX: 44-1794-519222

13.3 Teledyne Continental Motors, Inc. New Engine Warranty

Each new aircraft engine shipped from the Teledyne Continental Motors (TCM) plant on or after April 2, 2010 is warranted as follows:

1. (a) For a period of twenty-four (24) months or until the expiration of TCM's recommended Time Between Overhaul (TBO), whichever occurs first, after the warranty activation date TCM will, except as excluded below, at its option repair or replace on an exchange basis any engine, component or part manufactured or supplied by it which within the applicable twenty-four (24) month or TBO period is returned to a TCM representative authorized to handle the engine covered by this warranty and which upon examination is found to the satisfaction of TCM to be defective in material or workmanship. The warranty activation date is the date the engine is first operated for any use or the 180th day after TCM's invoice date, whichever occurs first. After the expiration of the first twelve (12) months of the applicable twenty-four (24) month period described above, TCM will not assume any responsibility for the repair or replacement of engine accessories, i.e. parts which have been purchased by TCM from a manufacturer as a complete and finished unit and included in the assembly of an engine without altering the unit, including, but not limited to, carburetors, starters, alternators, turbochargers and fuel controls. After the expiration of the initial twelve (12) month period, accessories will be subject to such warranty coverage as may be provided by their manufacturer.
- (b) TCM will pay for reasonable labor costs associated with repairs or replacements under paragraph 1(a) of this warranty and for "troubleshooting" costs associated with identifying the need for such repairs or replacements, when coordinated through an authorized TCM representative. The amount of repair and replacement labor costs allowed will be in accordance with the latest revision of the warranty labor allowance schedule, form X30552, published by TCM. The amount of "troubleshooting" costs allowed will be the reasonable costs under the circumstances of identifying the need for such repairs or replacements, but in no event will the "troubleshooting" costs allowed exceed fifteen percent (15%) of the labor costs associated with such repairs or replacements allowed by TCM. No "troubleshooting" cost

13. LIMITED WARRANTIES (Continued)

allowance will be made where the need for repairs or replacements is identified in the course of overhaul, routine maintenance or on the basis of an obvious defect.

- (c) TCM will pay transportation costs in connection with the repair or replacement of any engine, component or part found to the satisfaction of TCM to be defective in material or workmanship under paragraph 1(a) of this warranty. The engine, component or part must be shipped prepaid to the repair facility designated by TCM. Transportation cost reimbursement for engines will be the actual surface freight charge or \$500.00, whichever is less. Engines must be described on the bill of lading as follows: "Internal combustion engine, other than Radial Cyl RVNX \$5.00". Transportation cost reimbursement for components or parts will be the actual surface freight charge for shipment of the component or part or the currently published UPS surface rate schedule, whichever is less.
2. TCM reserves the right at its option to replace any defective engine or part with either a new or rebuilt engine or part.
3. Repair or replacement of any engine or part under this warranty will not extend the period of warranty coverage set forth above.
4. This warranty applies only to engines in which parts manufactured or supplied by TCM or parts manufactured pursuant to an FAA Parts Manufacturer Approval have been used and nothing contained herein should be construed as a warranty by TCM of any engine or part not manufactured or supplied by TCM. TCM accepts no responsibility for the failure of any engine or part which it does not manufacture or supply or damage resulting from such failure.
5. This warranty applies only to engines which have been installed, inspected and maintained in accordance with the instructions for continued airworthiness, including compliance with all applicable service bulletins issued by TCM, the aircraft manufacturer or any accessory or component manufacturer. Performance of recommended inspections and maintenance must be documented by appropriate logbook entries and the logbook must accompany any engine being returned for warranty consideration.
6. This warranty does not apply to any engine, component or part manufactured or supplied by TCM which (1) has been subject to misuse, neglect or accident; (2) has been installed, repaired, maintained or altered in any way that in the judgment of TCM has adversely affected the condition of the engine; (3) has been operated inconsistent with TCM and aircraft manufacturer recommendations and limitations (such as, but not limited to engine RPM, temperature, manifold pressure, fuel flow and proper system adjustment) or (4) has been changed from its original FAA certificated configuration.
7. TCM will not be responsible for repair or replacement of any engine, component or part damaged or worn as a result of corrosion, pre-ignition/detonation, operation with non-calibrated engine gauges, improper fuel system adjustment, non-TCM approved fuel and oil grades or additives or installation of parts, components or accessories that alter the engine's original type design.
8. The provisions of this warranty do not apply to normal maintenance service (such as engine tuneups, adjustments, inspections, engine or component overhaul resulting from time between overhaul (TBO) recommendations, etc.) or to the replacement of normal service items (such as spark plugs, filters, hoses, belts, etc.).
9. TCM reserves the right to change any engine or part specifications or prices without incurring any responsibility with regard to engines or parts previously sold or replaced.
10. **THIS WARRANTY IS A WARRANTY TO REPAIR OR REPLACE AND NOT A WARRANTY OF THE CONDITION OR FUTURE PERFORMANCE OF THE PRODUCTS WHICH IT COVERS. THERE ARE NO OTHER WARRANTIES, EXPRESSED OR IMPLIED, SPECIFICALLY, BUT WITHOUT LIMITATION, THERE ARE NO IMPLIED WARRANTIES OF MERCHANTABILITY OR FITNESS FOR A PARTICULAR PURPOSE. IN NO EVENT WILL TCM BE RESPONSIBLE FOR ANY INCIDENTAL OR CONSEQUENTIAL DAMAGES ARISING OUT OF ANY DEFECT IN ANY ENGINE OR PART, ARISING OUT OF THE FAILURE OF ANY ENGINE OR PART TO OPERATE PROPERLY, OR ARISING OUT OF ANY BREACH OF THE WARRANTY MADE HEREIN. NO PERSON IS AUTHORIZED TO GIVE ANY OTHER WARRANTY OR TO ASSUME ANY ADDITIONAL OBLIGATION OR LIABILITY ON BEHALF OF TCM.**



13. LIMITED WARRANTIES (Continued)

13.4 McCauley Propeller Systems Standard Limited Warranty

McCauley Propeller Systems, a Division of Cessna Aircraft Company, Wichita, Kansas, U.S.A., expressly warrants new and remanufactured products produced and sold by McCauley to be free from defects in material and workmanship under normal use and service for a period of thirty-six (36) months after delivery to the original retail purchaser or until the expiration of the maximum hours of use or calendar limits for overhaul published by McCauley for the subject product, whichever occurs first.

McCauley's obligation under this limited warranty is limited to repairing or replacing, at its sole option, any propeller, propeller parts, governor or governor parts determined by McCauley to have been defective and which are properly returned by the owner, with a written statement describing the alleged defect, to any McCauley Authorized Service Center authorized to service the individual McCauley product. The repair or replacement of defective parts will be made without charge to the owner for parts, or labor for removal and installation, except export/import duties, and/or sales or use taxes, if any which are solely the owner's responsibility. McCauley will warrant a part replaced pursuant to this limited warranty under the same terms as the original part for the remainder of the applicable warranty period of the original part. This limited warranty is not intended to and does not cover the costs of normal maintenance of overhaul.

In addition, McCauley will repair or replace, at its option, any propeller, propeller parts, governor, or governor parts requiring replacement due to manufacturing defect if found at or before the first recommended overhaul interval as described in McCauley published service information. This first overhaul coverage does not include labor, standard overhaul replacement parts, parts repairable via published service information (replating, painting, etc.), other costs associated with the propeller or governor overhaul, or export/import duties, and/or sales or use taxes, nor does it apply to defects found after McCauley published overhaul hour or calendar limits. The provisions of this limited warranty do not apply to: any McCauley parts which have been subject to misuse, negligence or accident or which have been repaired or altered in any way that, in the sole judgment of McCauley, adversely affects their performance, stability or reliability; to normal maintenance services (such as cleaning, mechanical adjustments and maintenance inspections); to the replacement of service items made in connection with normal maintenance; to normal deterioration of soft trim and appearance items (such as paint and rubber-like items) due to wear and exposure; to propellers, governors or parts found defective beyond the McCauley recommended overhaul period; or to parts which have been improperly installed by entities other

than McCauley and/or McCauley Authorized Service Centers.

The McCauley limited warranty is void on any new or remanufactured product installed, without McCauley's prior written approval, on a non-type certificated engine, or on any engine which has received an overhaul or modification which is not approved by the engine manufacturer and that results in a change to the vibratory environment of the engine such as, but not limited to, an alteration of horsepower, operating RPM, crankshaft damper configuration, compression ratio, magneto timing, camshaft design, or any other overhaul or modification not expressly approved by the original engine manufacturer. The McCauley limited warranty is also void on any McCauley product shipped new from the factory or distributor in disassembled state, then later re-assembled by an unauthorized party. Parties authorized to re-assemble factory-new product must have specific written permission from McCauley to do so, otherwise all McCauley warranty on the affected unit is void. No McCauley warranty coverage is offered for leakage on product assembled outside McCauley, regardless of the assembling party.

To the extent allowed by applicable law, **THIS WARRANTY IS EXPRESSLY IN LIEU OF ANY OTHER WARRANTIES, EXPRESSED OR IMPLIED IN FACT OR BY LAW, INCLUDING ANY IMPLIED WARRANTY OF MERCHANTABILITY OR FITNESS FOR A PARTICULAR PURPOSE. THE REMEDIES OF REPAIR OR REPLACEMENT SET FORTH HEREIN ARE THE ONLY REMEDIES UNDER THIS LIMITED WARRANTY. McCAULEY DISCLAIMS ANY OBLIGATION OR LIABILITY, WHETHER IN CONTRACT OR IN TORT, INCLUDING LOSS OF USE OF THE PRODUCT WARRANTED, LOSS OF TIME, INCONVENIENCE, LOSS OF PROFITS, COMMERCIAL LOSS, OR ANY OTHER DIRECT, CONSEQUENTIAL, SPECIAL, OR INCIDENTAL DAMAGES. THIS WARRANTY IS IN LIEU OF ANY OBLIGATION OR LIABILITY ON THE PART OF McCAULEY TO ANYONE OF ANY NATURE WHATSOEVER BY REASON OF THE MANUFACTURE, SALE, LEASE, OR USE OF THE WARRANTED PRODUCTS AND McCAULEY NEITHER ASSUMES NOR AUTHORIZES ANYONE TO ASSUME FOR IT ANY OTHER OBLIGATION OR LIABILITY IN CONNECTION WITH SUCH WARRANTED PRODUCTS. THE UNITED NATIONS CONVENTION ON CONTRACTS FOR THE INTERNATIONAL SALE OF GOODS, 1980, AND ANY SUCCESSOR THERETO, IS EXPRESSLY EXCLUDED FROM THIS WARRANTY.**

Issued 9/1/2003

13. LIMITED WARRANTIES (Continued)

13.5 Cessna Skycatcher Model 162 Paint Warranty

Cessna endeavors to select and use high quality polyurethane paints from the leading manufacturers. Polyurethane paints are used because of their high gloss characteristics and ability to withstand dramatic temperature and pressure changes. The paint on your new aircraft will maintain its high gloss characteristics for an extended period of time provided it is cared for properly.

The painted exterior surfaces require an initial curing period which may be as long as ninety (90) days after the finish is applied. During this curing period, some precautions should be taken to avoid damaging the finish or interfering with the curing process. The finish should be cleaned only by washing with clean water and mild soap, followed by a water rinse and drying with a cloth or chamois. Do not use polish or wax, which would exclude air from the surface, during this ninety (90) day curing period. Once the finish has cured completely, it may be waxed with a good automotive wax, but power buffing should be avoided to prevent damage to the paint surface.

Normal paint maintenance will include but is not limited to; touchup of abrasion and wear of the paint on screws heads, around access panels, wing leading edges, vertical and horizontal stabilizer leading edges, windshield retainers and other leading edge surfaces including parts on the landing gear subject to damage or erosion from airborne particles. Proper maintenance includes keeping surfaces clean, polished, and touching up chipped or eroded areas to prevent further damage and corrosion.

Paint and graphics warranty applies only to defects in material and workmanship for a period of one (1) year or 1,000 hours (whichever occurs first) from the warranty start date. Deterioration of paint and graphics due to normal wear, exposure, or improper care is not covered by the warranty. If proper paint maintenance procedures have been followed and paint peeling, blistering or cracking is evident in areas other than immediate leading edge surfaces, warranty consideration may be requested through a Cessna Service Station.

Generally speaking, warranty repair of paint is confined to a limited surface area. Workmanship or material defects can usually be identified to localized surface areas that were improperly prepared prior to paint appli-

cation, or to areas where the paint or subsurface primer has been improperly applied.

Complete strip and repaint of an entire airplane can ONLY be authorized if there is evidence of paint defects on several major surface areas of the aircraft. Contact your Cessna Field Service Engineer concerning paint defects on any major surface of an aircraft.

